



Basic Electricity Teacher Guides and Lessons for Grades 9-12

Lesson 1 - How is Electricity Transported?

Teacher's Guide

1. Pass out the info sheets "How is Electricity Transported - Basic Electricity Vocabulary." Spend 4-6 minutes looking at the pictures and reading the definitions. Have students put a check by any of the items they have seen before.
2. Pass out "How is Electricity Transported?" Allow the students 4-5 minutes to fill-in what they think are the correct steps. Have students work together in pairs or small groups for greater success.
3. Go over the answers as a class. Answer Key:

1) Power Generation Plant	5) power poles	8) breaker box
2) transmission substation	6) transformer drums	9) 240v outlet
3) high voltage transmission lines	7) residential end point	10) 120 v outlet
4) power substation		
4. As a class, read the "Safety Counts!!" box. Have the students guess where contact with electricity is safe. (There are none!)
5. Talk about electricity and safety. Be sure to talk about how electricity is potentially **fatal at all stages** along the transmission of electricity. *A very small amount of electricity, only 1 to 3 seconds of 0.006-0.2 Amps (that's 6-200mA- milliamps), can cause death. To provide an example of how small an amount of current it takes to kill; a 15-Watt night light draws about 125mA. So less than 1/20 the electricity used to power a small night light is fatal - OR - More than 20 people could be killed by the amount of electricity used by a small night light.*



Lesson 1 – How is Electricity Transported?

Teacher's Guide

6. If you have time, go out into the yard and find different steps in the transmission grid. Besides power poles and outlets, you might be able to find a breaker box and transmission drums. Note that some transmission lines – especially around schools - are typically buried.

Lesson 1 – How is Electricity Transported?

Basic Vocabulary



Appliance: Electric Clothes Dryer: An end-use device that runs on electricity.



120 Volt Outlet: Supplies electricity to most home appliances.



Power Plant: Generates electricity from another form of energy, such as burning gas or coal, water flow, solar energy or wind.



Transformer Drums: Convert electricity to lower voltage for use in a house.



Power Substation: A high-voltage electric facility used to lower or raise voltage, change the type of current, and direct the flow of electricity.



Appliance: Table Lamp: An end use device that converts electricity into light.

Lesson 1 – How is Electricity Transported?

Basic Vocabulary



240 Volt Outlet: Supplies electricity for large appliances, such as clothes dryers and stoves.



Power Poles: Carries lower voltage electricity from substations to houses.



House: Residential endpoint of electricity.



High-Voltage Transmission Lines: Carry high-voltage current from Power Plants.



Transmission Substation: Controls the transmission of electricity into a high-voltage network from a power plant.



Breaker Box: Controls and regulates the flow of electricity in a house.

Lesson 1 – How is Electricity Transported?

Directions: Based on what you now know about electricity, use the terms below to fill in the steps of the transmission of electricity from the power plant to the household appliances.

	1	<i>Power Generation Plant</i>
	2	
	3	
	4	
	5	
	6	
	7	
	8	



Power Poles



Residential Endpoint



240 V Outlet



Transmission Substation



120 V Outlet



High Voltage Transmission Lines

SAFETY COUNTS!!!

Where along the path of transmission is it safe to come in contact with the electricity?

⊕ Circle the step number(s) where you think it would be safe if you were to accidentally come in contact with the electric current.

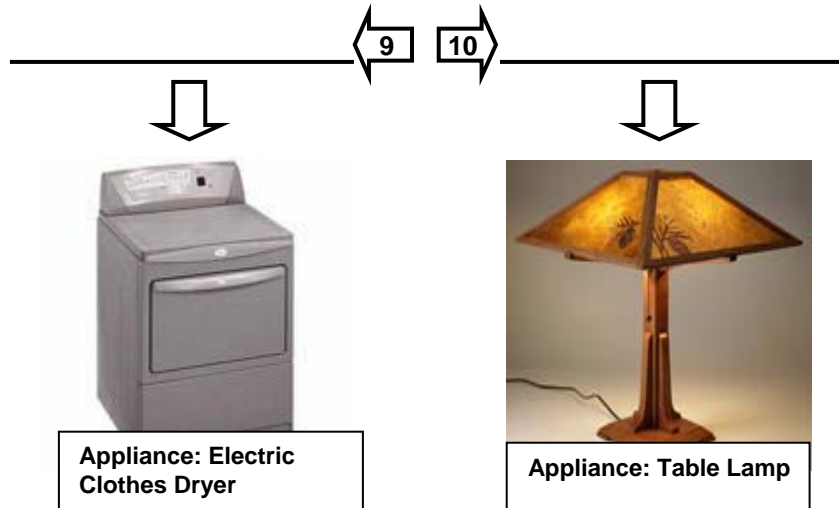

Lesson 2 – Basic Understanding

Teacher's Guide

1. Pass out the worksheets and have the students spend a minute reading through the **Key Words**, checking the ones they know something about.

2. Have students work for 7-10 min in pairs or small groups to carefully read and complete **A) What is electricity?** and **B) What is a circuit?**

Read the section aloud as a class clarifying the correct answers.

Answer Key:

- | | |
|-------------------------------------|----------------------|
| A) What is Electricity | B) What is a circuit |
| 1. atoms | 1. circuit |
| 2. protons and neutrons, electrons | |
| 3. a) proton b) neutron c) electron | |

Extension: The circuit diagram represents a single-cell flashlight. Have a volunteer draw a circuit diagram for a two-cell flashlight with the switch open. Have students look up symbols for other electrical components.

3. Have student groups work through **C) Which of these are closed circuits that will light the bulb?** for 3-5 minutes.

Discuss their answers and their reasoning. Do not correct errors at this point if you have the materials for the students to test their responses.

Extension: 1) Have students mark which end of the battery is positive (+) and which is negative (-) and draw arrows on the diagrams to show the path of electricity from the negative terminal to the positive terminal.

2) Have students draw circuit diagrams of one or more of the circuits that they think are closed.

4. If the materials are available, have the student groups spend 10-15 minutes doing **D) How many ways can you light a bulb ?**

- | | | |
|-------------|-----------------------------|---------------------------------|
| Answer Key: | 1) open | 4) closed – bulb will light |
| | 2) open | 5) open |
| | 3) closed – bulb will light | 6) closed – bulb will NOT light |

Lesson 2 – Basic Understanding

Teacher's Guide

Extension: Discuss why #6 will not light even though the circuit is closed. Have students study a light bulb and determine where the contact needs to be made in order to have a pathway for the current through the filament of the bulb. Make a labeled diagram.

5. Read aloud as a class **E) How can you be safe around electricity?** Have students share experiences they've had or heard about "becoming a conductor of electricity" and how it could be avoided in the future.

Lesson 2 – Basic Understanding

Key Words: Place a check by the words you already know something about. You will use some of the words to fill in the blanks below.

electricity	nucleus	circuit	conductors
atoms	protons	open circuit	electric current
electrons	neutrons	closed circuit	

A) What is electricity? Electricity is a form of energy carried by the movement of electrons.

1. Everything that is a solid, liquid or gas is made up of tiny particles called _____, which are too small to be seen, even with a microscope.
2. A single atom is made up of a center of _____ and _____ called the nucleus around which _____ orbit.
3. Protons have a positive electric charge, while electrons have an equal and opposite negative electric charge.

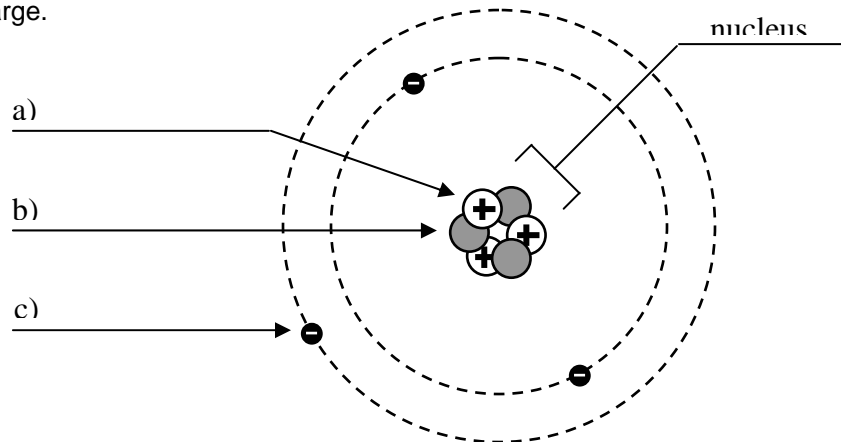

4. Label the parts of the atom above.
5. The outer electrons of some atoms, like those of copper and other metals, are only loosely held in place and so can easily move to other atoms. These types of materials are called conductors.
6. An outside force – such as magnetism, a chemical reaction, light or heat – can put electrons into motion. When electrons flow continuously from atom to atom through a conductor an electric current is created.

Lesson 2 – Basic Understanding

B) What is a circuit? A circuit is a closed loop through which electricity flows.

1. In order to form an electric current electrons must have a continuous path, called a _____.
In a simple circuit, the electricity flows from the power source, such as a battery, through a wire to a device, such as a light bulb, and then back again to the battery, in a closed loop.

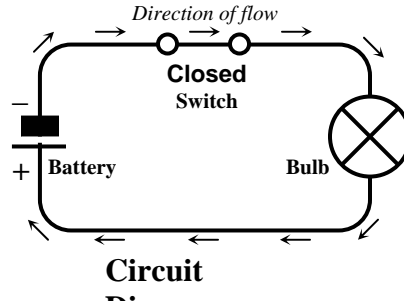

2. When the circuit is closed, as in this circuit diagram, the electricity has a continuous path to and from the battery, so the bulb will light.
3. If the circuit is open, for example by opening the switch, the path will become broken and the bulb will not light.

C) Which of these are closed circuits that will light the bulb?

1) Open
 Closed

2) Open
 Closed

3) Open
 Closed

Lesson 2 – Basic Understanding

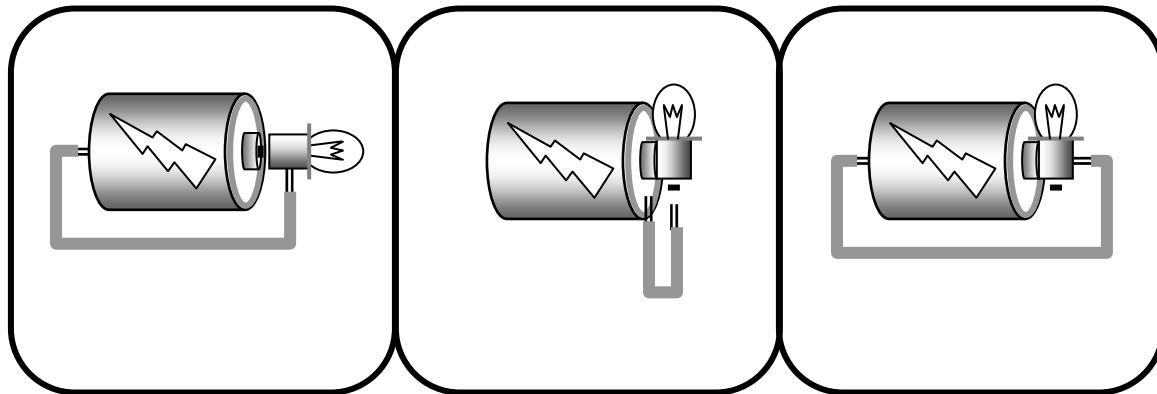

4) Open
 Closed

5) Open
 Closed

6) Open
 Closed

D) How many ways can you light a bulb ?

Materials: Battery (Size 'D') Wire (2 pieces, 150cm/5in, insulated with ends stripped) Bulb

1. Using a battery, two pieces of wire and a bulb, try making each of the circuits in the above diagrams to see if your guesses were right.
2. Try using the same materials to find as many other ways to light the bulb as you can. On a separate piece of paper, diagram each of your attempts.

E) How can you be safe around electricity?

Water is a conductor of electricity, and since the human body is mostly water, you are a conductor too! Follow these guidelines to avoid becoming a dangerous pathway for electricity.

- Avoid making contact with the electricity in appliances, power cords or power lines.
- Make sure your hands are dry before you touch anything electrical.
- Keep yourself, any tools, or equipment – such as ladders – at least 10 feet away from all overhead power lines.

REMEMBER: Contact with high-voltage electricity from power lines, or low-voltage electricity from household sources can be fatal !

Lesson 3 – Measuring Electricity

Teacher's Guide

6. Pass out the worksheets and have the students spend a minute reading through the **Key Words**, checking the ones they know something about.
7. Have students work for 2-3 min alone or in pairs or small groups to carefully read and complete **A) How is electricity measured ?**

Then read the section aloud as a class clarifying the correct answers.

Answer Key:

1. amperage, voltage, wattage
 2. 2 cells, 2.4V, 0.5A, 1.2W
8. Work through **B) How can energy use be calculated?** as a class for 4-6 minutes, including the examples of each of the four formulas and the sample problem.
 9. Have students work in pairs or small groups to solve the two problems in part **C)** for 10-12 minutes. Share and discuss the solutions as a whole class.

1. • If he uses 100 watt bulbs, how much will it cost to leave both lights on for 30 days for 12 hours each night at an electricity rate of \$.08 per kWh?

- 1) **Convert watts to kW (W / 1000)** $100W / 1000 \times 2 \text{ bulbs} = 0.2kW$
- 2) **Calculate kWh (kW x hours)** $0.2kW \times 12hrs \times 30days = 72kWh$
- 3) **Calculate cost (kWh x \$.08)** $72kWh \times \$.08 = \5.76

Cost: **\$5.76**

• How much cheaper would it be if you changed the light bulbs to 60 watts each?

- 1) **Convert watts to kW (W / 1000)** $60W / 1000 \times 2 \text{ bulbs} = 0.12 \text{ kW}$
- 2) **Calculate kWh (kW x hours)** $0.12kW \times 12hrs \times 30days = 43.20kWh$
- 3) **Calculate cost (kWh x \$.08)** $43.20kWh \times \$.08 = \3.46

Cost: **\$3.46**

Difference:

2. • How much will it cost to run a 240 volt air conditioner drawing 11 amps, 8 hours a day for 30 days at \$.08 kWh?

- 1) **Calculate the watts (A x V)** $11A \times 240V = 2640W$
- 2) **Convert watts to kW (W / 1000)** $2640W / 1000 = 2.64kW$
- 3) **Calculate kWh (kW x hours)** $2.64kW \times 8hrs \times 30days = 633.60kWh$
- 4) **Calculate cost (kWh x \$.08)** $633.60kWh \times \$.08 = \50.69

Cost: **\$50.69**

Lesson 3 – Measuring Electricity

Teacher's Guide

Extension: **Have students suggest ways to lower the monthly cost, including researching air conditioners that draw less power, then recalculate the problem to determine the most cost effective suggestion.**

5. **Have student groups spend 5-7 min using the data provided in D) to write their own problems. After the students have exchanged and worked the problems, check the solutions by having students share them with the whole group on the board or overhead.**
6. Read aloud as a class, **REMEMBER: Electricity can kill!** Share examples of deadly practices (examples: leaving the power on when replacing an outlet or switch, touching an electric radio or clock while in the bath, running electric cords under carpets, etc...)

Lesson 3 – Measuring Electricity

Key Words: Place a check by the words you already know something about. You will use some of the words to fill in the blanks below.

amperage (amps)	kilowatt
voltage (volts)	kilowatt hour
wattage (watts)	

A) How is electricity measured ? Electricity is measured in terms of amps, volts and watts.

- The flow of electricity through a wire can be likened to the flow of water through a hose. Like water flowing through a hose, electricity has volume, pressure and power to do work. The current or amount of electricity flowing is measured as _____ (amps). The force or pressure of the current is measured as _____ (volts). The work that the electricity does, which is the power gotten from the current, is measured as _____ (watts).
- For example, flashlight bulbs are identified by Volts, Amps and Watts as well as by their base and the number of cells (batteries) used to light them. According to the table below, a GV2405 light bulb would require _____ cells to produce _____ volts of force to move _____ amps and use _____ watts of power.

Code	Base	V	A	W	Qty of Cells
GV1225	Screw-cap	1.25V	0.25A	0.31W	1
GV2405	Screw-cap	2.4V	0.5A	1.2W	2
GV245	Push-in	2.4V	0.5A	1.2W	2
GV3502	Screw-cap	3.5V	0.2A	0.7W	3

- The work that can be done by a device (watts) depends upon both the amount (amps) and pressure (volts) of the current, and is expressed as: watts = volts x amps.

B) How can energy use be calculated?

Formulas

- Power: Watts = Volts x Amps ($W = V \times A$)

$$120V \times 8.33A = 1000W$$

- Useful unit of power: kiloWatt (kW) = Watts/1000 ($kW = W / 1000$)

$$1000W / 1000 = 1kW$$

- Power used per hour: kiloWattHour (kWh= kiloWatt x hours of operation ($kWh = kW \times h$)

$$1kW \times 24 \text{ hours} = 24kWh$$

- Cost of power use: kiloWattHour x cost per hour (currently \$.08) ($kWh \times .08$)

$$24 kWh \times .08$$

Lesson 3 – Measuring Electricity

Sample: Calculate the hourly cost of using a 1500W Plasma TV system with surround sound.

- 1) **Convert watts to kW** *1500 watts divided by 1000 = 1.5kW*
- 2) **Calculate kWh (kW x hours of operation)** *1.5 kW x 1 hour of operation = 1.5kWh*
- 3) **Calculate cost (kWh x .08)** *1.5kWh x \$.08 = \$.12*

C) Now try these problems. Show your work in the space provided.

1. Your uncle is trying to make his home more burglar proof. He decides to leave the front and back porch light on all night to scare off the bad guys. He asks you to figure out if leaving the lights on will cost a lot of money.

- If he uses 100 watt bulbs, how much will it cost to leave both lights on for 30 days for 12 hours each night at an electricity rate of \$.08 per kWh?

4) **Convert watts to kW (W / 1000)**

5) **Calculate kWh (kW x hours)**

6) **Calculate cost (kWh x \$.08)**

Cost:

- How much cheaper would it be if you changed the light bulbs to 60 watts each?

Cost:
Difference:

2. You tell your parents that you can't sleep at night during the hot summer months. They agree to install an air conditioner unit if you will pay the monthly cost of running it. It is a 240 volt unit drawing 11 amps. The first month (30 days) you run the unit 8 hours each day.

- How much will it cost at \$.08 kWh?

Cost:

D) On a separate piece of paper, work with a partner and use some of the data below to write up a problem of your own. Exchange problems with another group and solve.

- | | |
|--------------------------------------|------------------------------|
| Computer playing a game: 110W | Computer sleeping: 4W |
| Stereo System: 250W | Radio: 71W |
| Color TV: 200W | VCR: 45W |
| Waterbed: 375W | Jacuzzi: 1500W |

REMEMBER: Electricity can kill! Even a current as small as the .025 amps drawn by an electric clock can be enough to interfere with your heartbeat. So always avoid making contact with the electricity in appliances, power cords or power lines.